

ITEM NO.	PART NUMBER	DESCRIPTION	QTY.
1	92008	SET SCREW, CUP POINT 8-32, 3/16" L.	1
2	P23003/00	KG BACKPLATE	1
3	P23060	KG40 POST FOR TOWEL RING	1
4	11056/00	6" TOWEL RING	1
5	P36005/00	#6 DRY WALL SCREW	1
6	P39001	HEX KEY 5/64, FOR 8-32 SET SCREW	1
7	P23085	TOGGLER FOR WALL	1



ZONE	REV.	DESCRIPTION	DATE	APPROVED
A1	A	UPDATE TEMPLATE, DWG NAME	6/22/2020	AMM
REVISIONS				

1261 LOGAN AVENUE
COSTA MESA, CALIFORNIA 92626
PHONE: 714.361.4800
FAX: 714.617.3120

PHYLIRICH[®]
Defining Luxury Since 1959

PROPRIETARY AND CONFIDENTIAL

THE INFORMATION CONTAINED IN THIS DRAWING IS THE SOLE PROPERTY OF PHYLIRICH. ANY REPRODUCTION IN PART OR AS A WHOLE WITHOUT THE WRITTEN PERMISSION OF PHYLIRICH IS PROHIBITED.

-	-	INTERPRET GEOMETRIC DIMENSIONING & TOLERANCING IN ACCORDANCE WITH ASME Y14.5-2009 & ASME Y14.41-2003 STANDARDS, UNLESS OTHERWISE SPECIFIED. DIMENSIONS ARE IN INCHES. TOLERANCES ARE:		
NEXT ASSY	USED ON	FRACTIONS ±1/16"	DECIMALS X.X: ±.1 X.XX: ±.01 X.XXX: ±.005	ANGULAR ±2°
APPLICATION		MATERIAL	NAME	DATE
FINISH		DRAWN	LLO	8/27/2013
DO NOT SCALE DRAWING		CHECKED	GRE	

TOWEL RING, SMALL POST, REVERE & SAVANAH

SIZE	ASM/PRT NO.	REV
A	KG40/00	A
SCALE: 1:2	WEIGHT: lbs.	SHEET 1 OF 2

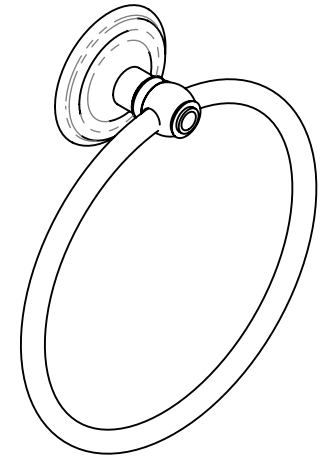
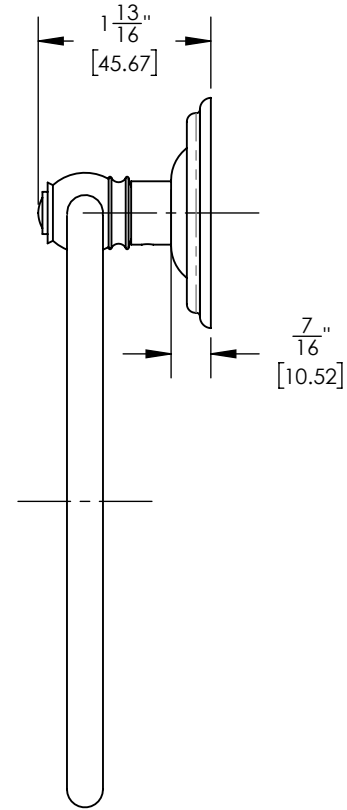
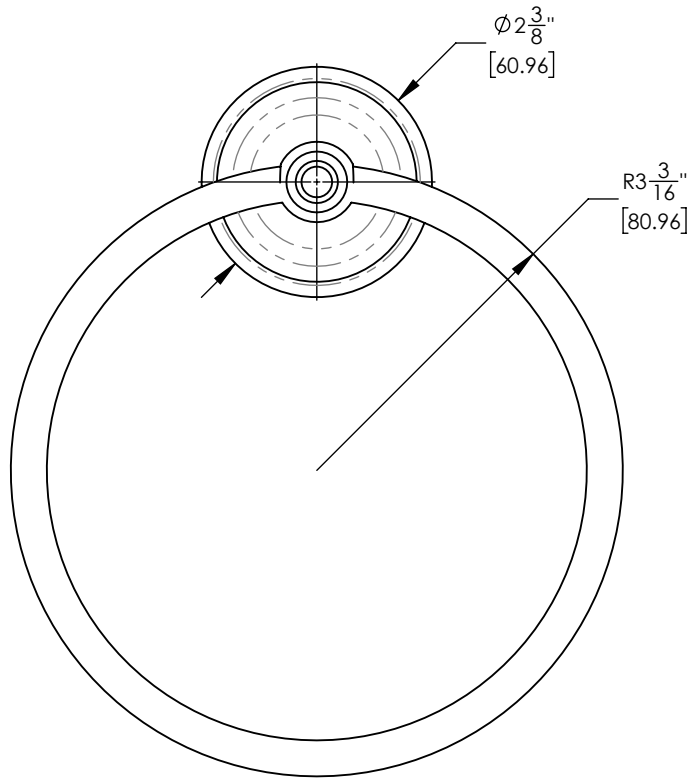

1261 LOGAN AVENUE
 COSTA MESA, CALIFORNIA 92626
 PHONE: 714.361.4800
 FAX: 714.617.3120

PHYLIRICH[®]
 Defining Luxury Since 1959

PROPRIETARY AND CONFIDENTIAL
 THE INFORMATION CONTAINED IN THIS DRAWING
 IS THE SOLE PROPERTY OF PHYLIRICH. ANY
 REPRODUCTION IN PART OR AS A WHOLE
 WITHOUT THE WRITTEN PERMISSION OF PHYLIRICH
 IS PROHIBITED.
DO NOT SCALE DRAWING

**TOWEL RING, SMALL POST, REVERE &
 SAVANAH**

SIZE A	ASM/PRT NO. KG40/00	REV A
SCALE: 1:2	WEIGHT: lbs.	SHEET 2 OF 2