

5 4 3 2 1

E
D
C
B
A

E
D
C
B
A

ITEM NO.	PART NUMBER	DESCRIPTION	QTY.
1	11204/00	PLATE, TWO HANDLE FLAT RADII EDGE	1
2	3-329/00	SUB ASSY. KNURLED HANDLE, BASIC II	2
2.1	2-247/00	HANDLE KNURLED, BASIC II	1
2.2	11164/00	ESCUTCHEON BASE, CONTEMP. BASIC II	1
2.3	90031	O-RING, 1-3/4"ID X 1/16"THK, AS-568-031	1

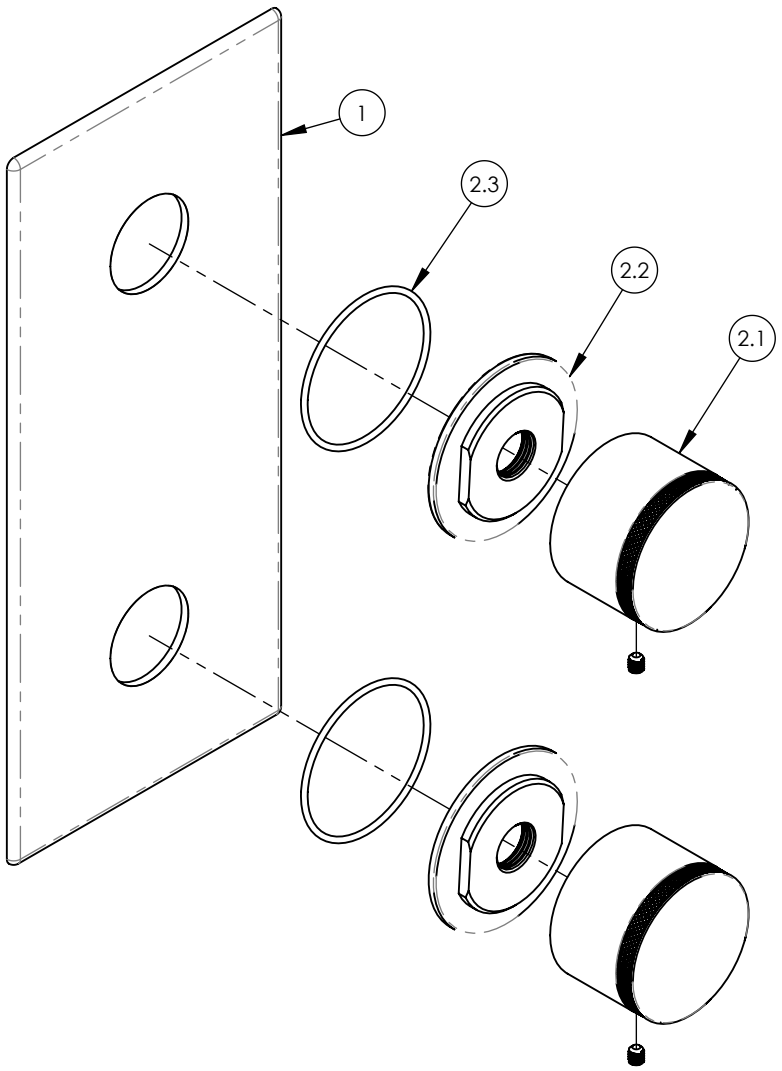

ALL	REV.	DESCRIPTION	DATE	APPROVED
A		UPDATE TEMPLATE, EXPLODE MORE, REMOVE TAPE	4/30/2020	AMM

1261 LOGAN AVENUE
COSTA MESA, CALIFORNIA 92626
PHONE: 714.361.4800
FAX: 714.617.3120

PHYLIRICH[®]
Defining Luxury Since 1959

PROPRIETARY AND CONFIDENTIAL
THE INFORMATION CONTAINED IN THIS DRAWING IS THE SOLE PROPERTY OF PHYLIRICH. ANY REPRODUCTION IN PART OR AS A WHOLE WITHOUT THE WRITTEN PERMISSION OF PHYLIRICH IS PROHIBITED.

-	-	INTERPRET GEOMETRIC DIMENSIONING & TOLERANCING IN ACCORDANCE WITH ASME Y14.5-2009 & ASME Y14.41-2003 STANDARDS, UNLESS OTHERWISE SPECIFIED. DIMENSIONS ARE IN INCHES. TOLERANCES ARE:		
-	-			
-	-			
NEXT ASSY	USED ON	FRACTIONS ±1/16"	DECIMALS X.X: ±.1 X.XX: ±.01 X.XXX: ±.005	ANGULAR ±2°
APPLICATION				
MATERIAL				
FINISH	DRAWN	NAME	DATE	
		LLO	3/11/2015	
DO NOT SCALE DRAWING		CHECKED	GRE	

1/2" MINI THERM. TRIM, 2 HANDLE KNURLED, BASIC II		
SIZE	ASM/PRT NO.	REV
A	4-168/00	-
SCALE: 1:2	WEIGHT: lbs.	SHEET 1 OF 2

5 4 3 2 1

A

A

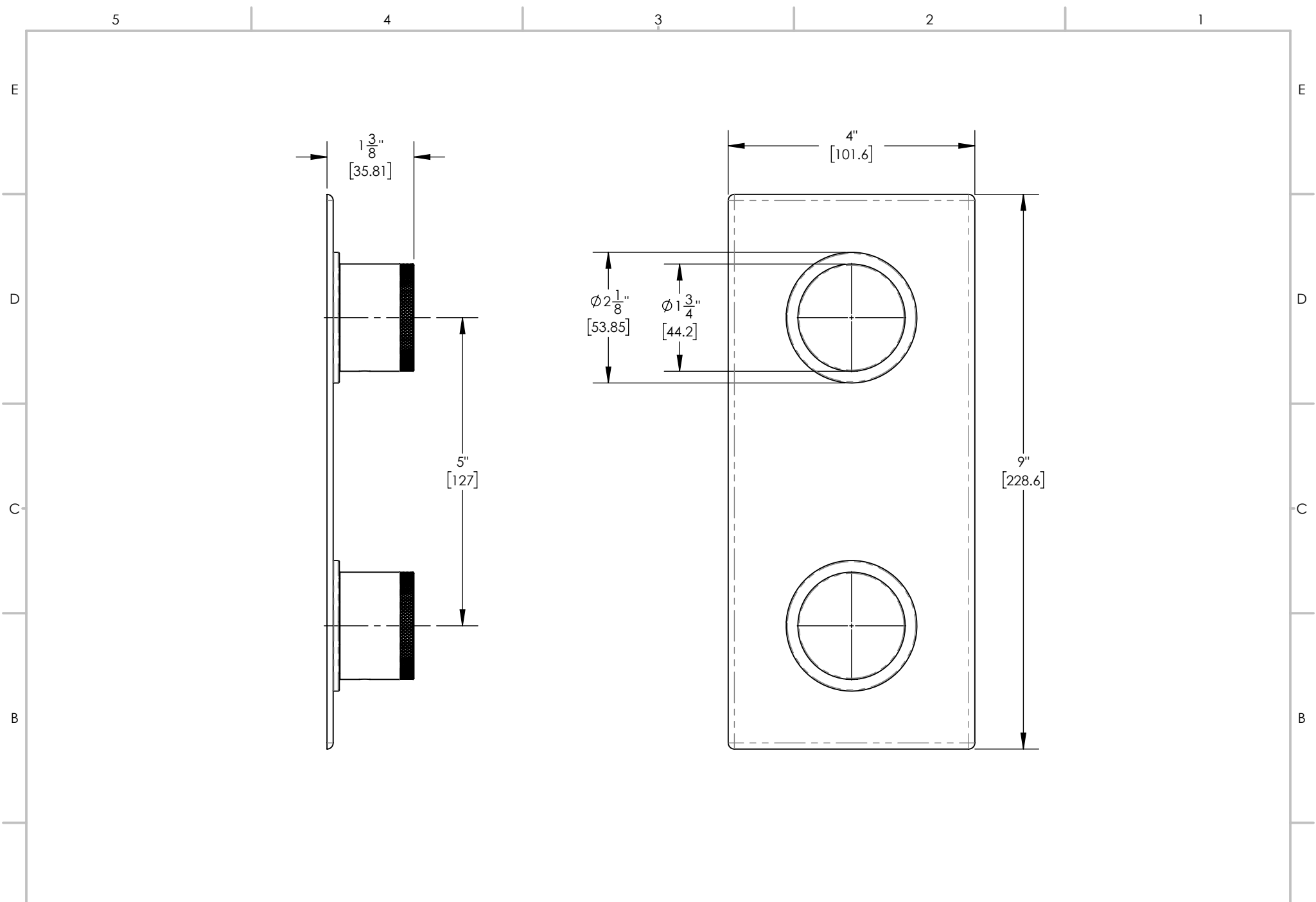

1261 LOGAN AVENUE
 COSTA MESA, CALIFORNIA 92626
 PHONE: 714.361.4800
 FAX: 714.617.3120

PHYLIRICH[®]
 Defining Luxury Since 1959

PROPRIETARY AND CONFIDENTIAL
 THE INFORMATION CONTAINED IN THIS DRAWING IS THE SOLE PROPERTY OF PHYLIRICH. ANY REPRODUCTION IN PART OR AS A WHOLE WITHOUT THE WRITTEN PERMISSION OF PHYLIRICH IS PROHIBITED.
DO NOT SCALE DRAWING

1/2" MINI THERM. TRIM, 2 HANDLE
 KNURLED, BASIC II

SIZE A	ASM/PRT NO. 4-168/00	REV -
SCALE: 1:2	WEIGHT: lbs.	SHEET 2 OF 2

A

A