

NOTE(S):
 1. PART NUMBER, "/00" DENOTES PART SHALL HAVE FINISH.

2. APPLY NSF COMPLIANT GREASE TO ANY O-RING, SEALING JOINTS, AND/OR PIVOTAL POINTS.

3. APPLY NSF COMPLIANT LOCTITE TO THREADED AREA.

4. APPLY NSF COMPLIANT REMOVABLE (BLUE) LOCTITE TO THREADED AREA.

5. SILVER SOLDER JOINTS SHALL BE FULLY WETTED VIA CAPILLARY ACTION AND COMPLETELY NON-POROUS.

6. EXAMPLE OF SPLIT FINISH CODE:
 A. 3-373/026X030

7. SPLIT FINISH CODES:

- A. BLACK MARBLE = 3-373/00X030
- B. WHITE MARBLE = 3-373/00X031
- C. SOAPSTONE = 3-373/00X032

8. AVAILABLE HANDLE STONE PART # OPTIONS:

- A. BLACK MARBLE = 11328 (030)
- B. WHITE MARBLE = 11329 (031)
- C. SOAPSTONE = 11330 (032)

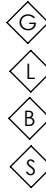

ITEM NO.	PART NUMBER	DESCRIPTION	QTY.
1	3-322/00	DIVERTER EXTENSION FOR PB TUB & SHOWER SET, HEX	1
2	3-373/00	MARBLE LEVER HANDLE ASSY., WALL/SHOWER	1
2.1	2-142/00	MARBLE LEVER HANDLE, 500 SERIES, HEX TRADITIONAL	1
2.2	10618/00	ESCUTCHEON, TRADITIONAL 500	1
2.3	10621/00	BASE HUB NUT	1
3	11087	SLEEVE FOR PB-THERM PLATE	1
4	P17011/00	TRIM PLATE, PRESSURE BALANCE, SMOOTH, DOUBLE HOLE	1

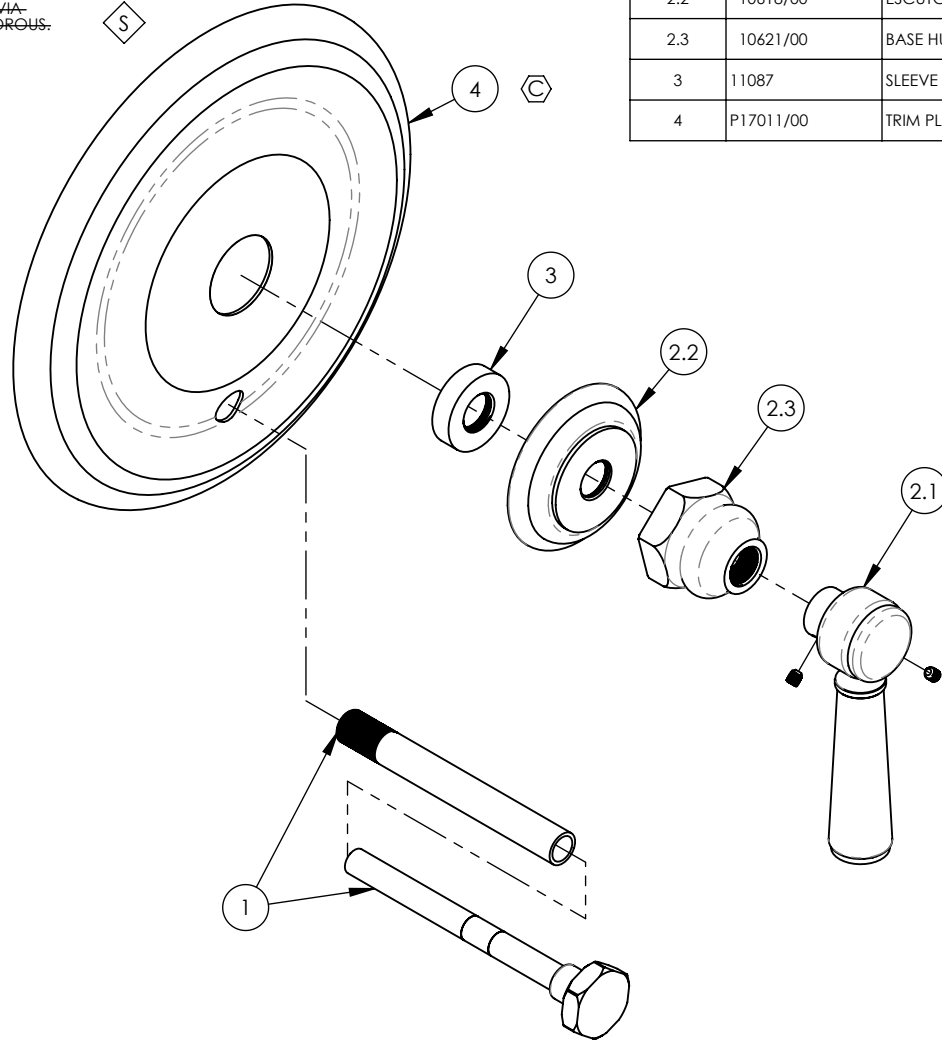

D4	C	UPDATE TRIM PLATE	4/23/2021	AMM
ZONE	REV.	DESCRIPTION	DATE	APPROVED
REVISIONS				

1261 LOGAN AVENUE
 COSTA MESA, CALIFORNIA 92626
 PHONE: 714.361.4800
 FAX: 714.617.3120

PHYLIRICH[®]
 Defining Luxury Since 1959

PROPRIETARY AND CONFIDENTIAL
 THE INFORMATION CONTAINED IN THIS DRAWING IS THE SOLE PROPERTY OF PHYLIRICH. ANY REPRODUCTION IN PART OR AS A WHOLE WITHOUT THE WRITTEN PERMISSION OF PHYLIRICH IS PROHIBITED.
DO NOT SCALE DRAWING

SHOWER TRIM PLATE, PB, DIVERTED,
 MARBLE, HEX TRAD

SIZE A	ASM/PRT NO. 4-164/00	REV C
SCALE: 1:2.5	WEIGHT: lbs.	SHEET 1 OF 2

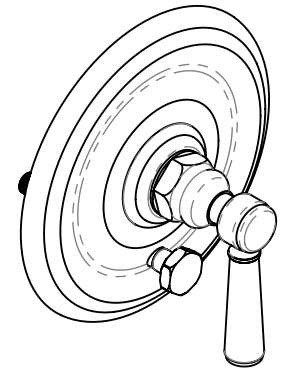
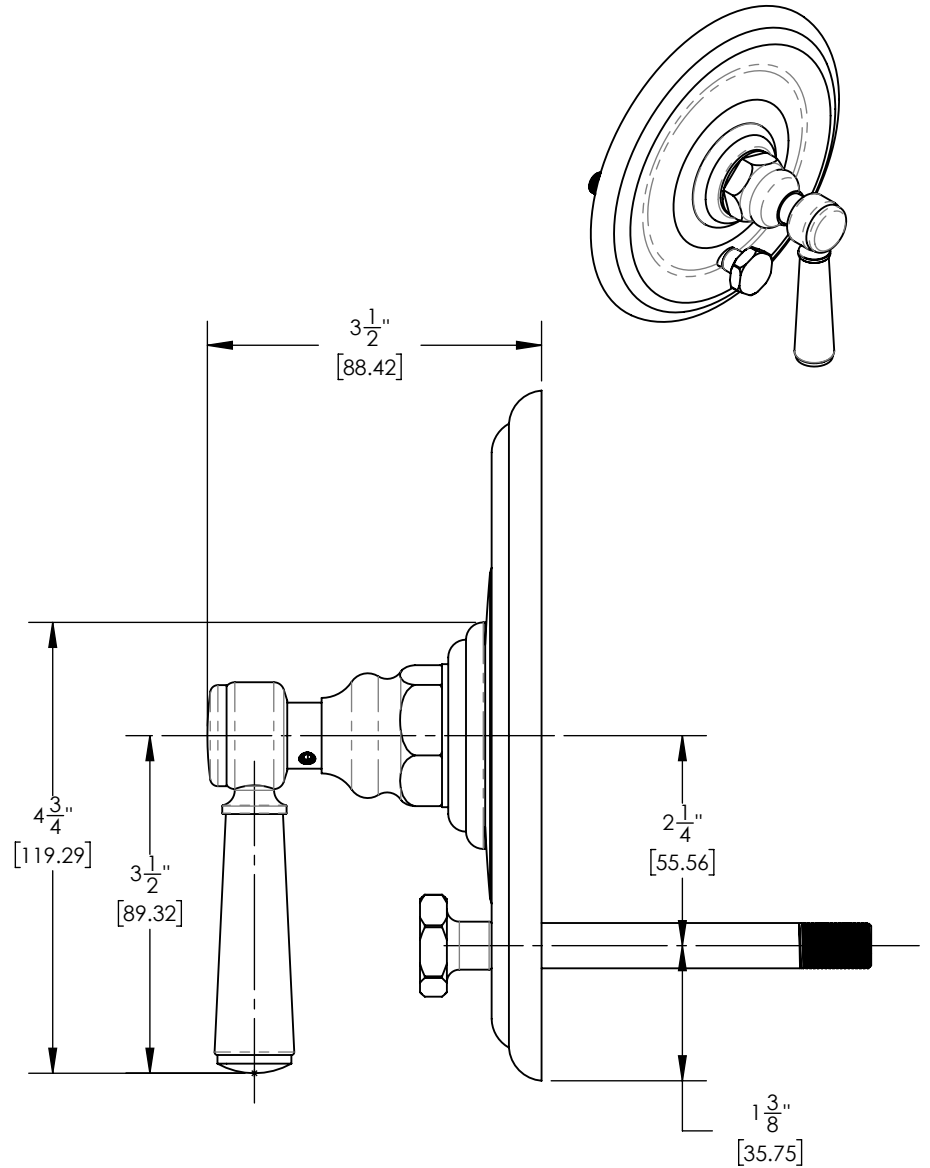
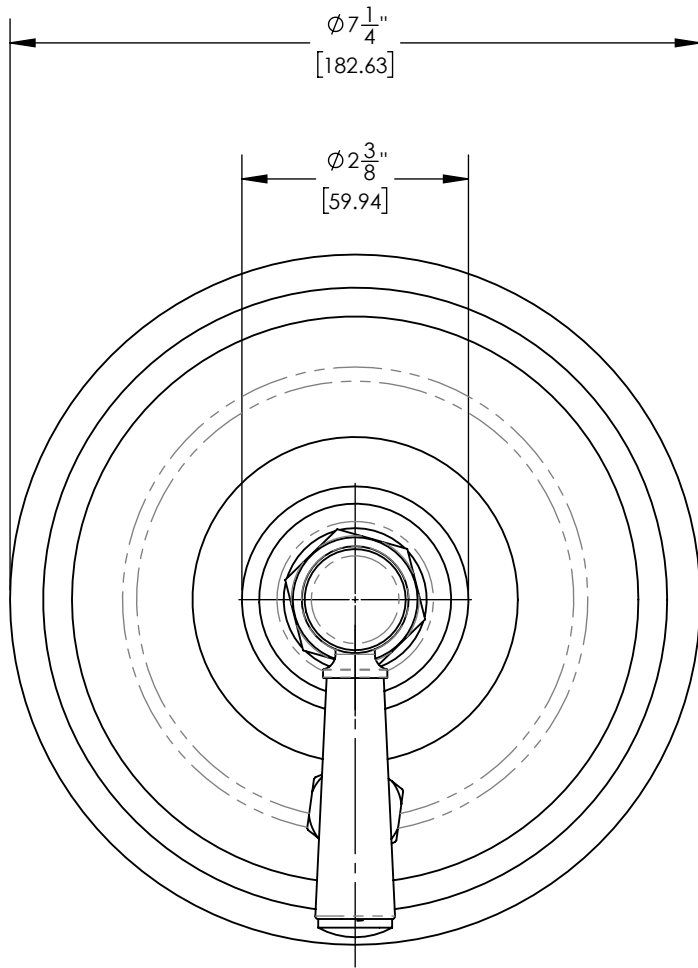

1261 LOGAN AVENUE
 COSTA MESA, CALIFORNIA 92626
 PHONE: 714.361.4800
 FAX: 714.617.3120

PHYLIRICH[®]
 Defining Luxury Since 1959

PROPRIETARY AND CONFIDENTIAL
 THE INFORMATION CONTAINED IN THIS DRAWING IS THE SOLE PROPERTY OF PHYLIRICH. ANY REPRODUCTION IN PART OR AS A WHOLE WITHOUT THE WRITTEN PERMISSION OF PHYLIRICH IS PROHIBITED.
DO NOT SCALE DRAWING

SHOWER TRIM PLATE, PB, DIVERTED,
 MARBLE, HEX TRAD

SIZE A	ASM/PRT NO. 4-164/00	REV C
SCALE: 1:2	WEIGHT: lbs.	SHEET 2 OF 2