

- NOTE(S):
1. PART NUMBER, "/00" DENOTES PART SHALL HAVE FINISH.
  2. APPLY NSF COMPLIANT GREASE TO ANY O-RING, SEALING JOINTS, AND/OR PIVOTAL POINTS.
  3. APPLY NSF COMPLIANT LOCTITE TO THREADED AREA.
  4. APPLY NSF COMPLIANT REMOVABLE (BLUE) LOCTITE TO THREADED AREA.
  5. SILVER SOLDER JOINTS SHALL BE FULLY WETTED VIA CAPILLARY ACTION AND COMPLETELY NON-POROUS.

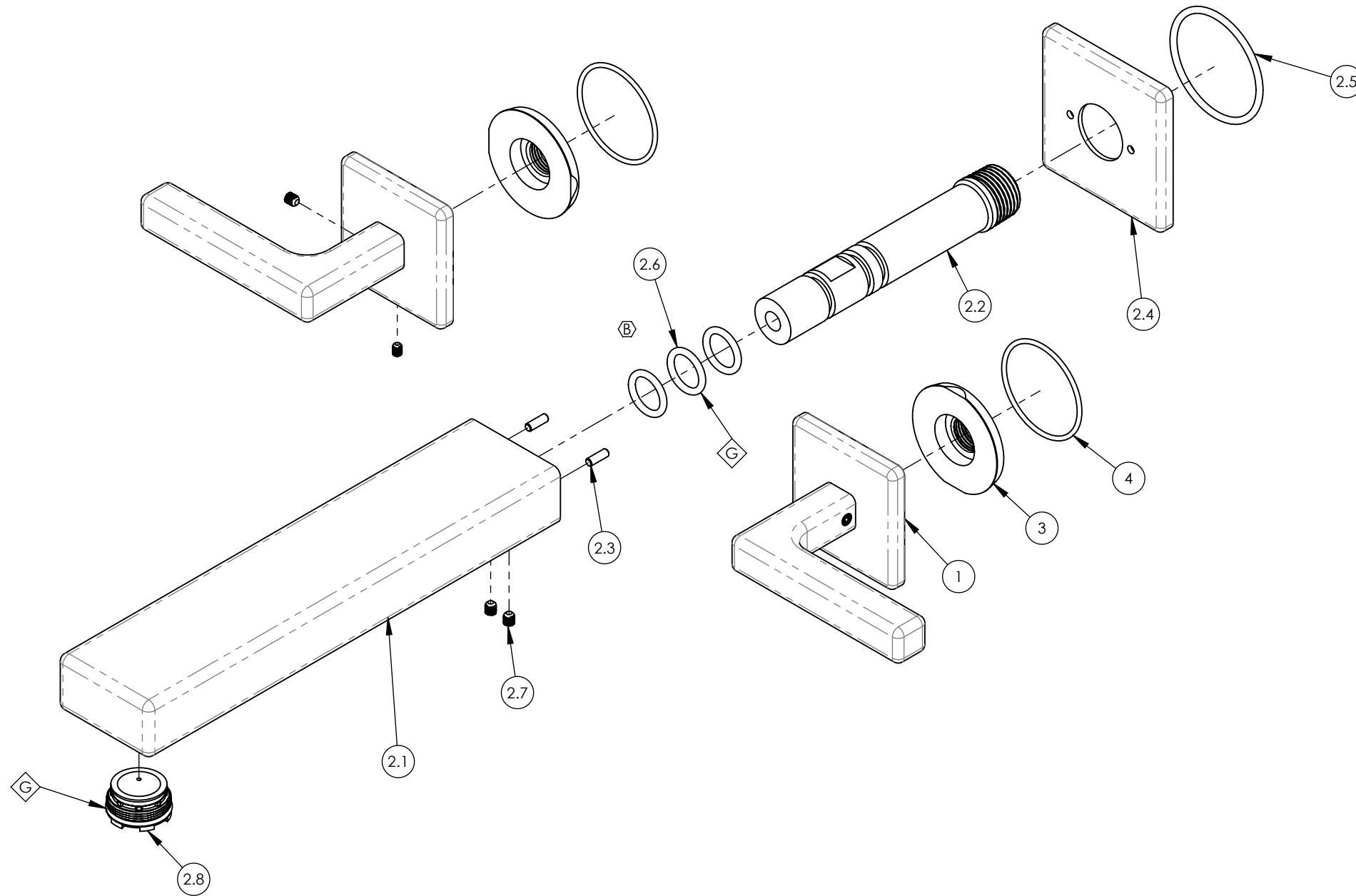

ITEM NO.	PART NUMBER	DESCRIPTION	QTY.
1	3-100/00	ASSY, HANDLE LEVER MIX SERIES	2
2	3-124/00	SPOUT, WALL TUB, MIX	1
2.1	11000/00	SPOUT, WALL MOUNT	1
2.2	10013	INJECTOR SHANK, 1/2"NPT MALE TO M16.5 CACHE W/ O-SEAL	1
2.3	92158	DOWEL PIN, 1/8" X 3/8"L	2
2.4	10934/00	ESCUTCHEON, SPOUT RT MIX SERIES	1
2.5	90131	O-RING, 1-11/16ID X 3/32THK, AS-568-131	1
2.6	90113	O-RING, 9/16"ID X 3/4"OD X 3/32"THK, AS-568-113	3
2.7	92008	SET SCREW, CUP POINT 8-32, 3/16" L.	2
2.8	P05051	AERATOR, CACHE COINED SLOT M24X1.0 FULL FLOW	1
3	11003	SLEEVE MOUNT, WALL MT WIDESPREAD	2
4	90029	O-RING, 1-5/8"ID X 1-3/4"OD X 1/16"THK, AS-568-029	2



C5	B	DESCRIPTION	DATE	APPROVED
		REMOVE SHANK EXTENSION, UPDATE O-RINGS	6/9/2021	AMM
ZONE	REV.	DESCRIPTION	DATE	APPROVED
REVISIONS				

1261 LOGAN AVENUE  
 COSTA MESA, CALIFORNIA 92626  
 PHONE: 714.361.4800  
 FAX: 714.617.3120

**PHYLIRICH**<sup>®</sup>  
 Defining Luxury Since 1959

**PROPRIETARY AND CONFIDENTIAL**  
 THE INFORMATION CONTAINED IN THIS DRAWING IS THE SOLE PROPERTY OF PHYLIRICH. ANY REPRODUCTION IN PART OR AS A WHOLE WITHOUT THE WRITTEN PERMISSION OF PHYLIRICH IS PROHIBITED.  
**DO NOT SCALE DRAWING**

**WALL TUB SET, LEVER, MIX**

SIZE <b>B</b>	ASM/PRT NO. <b>290-57/00</b>	REV <b>B</b>
SCALE: 1:2	WEIGHT: lbs.	SHEET 1 OF 2

8 7 6 5 4 3 2 1

E

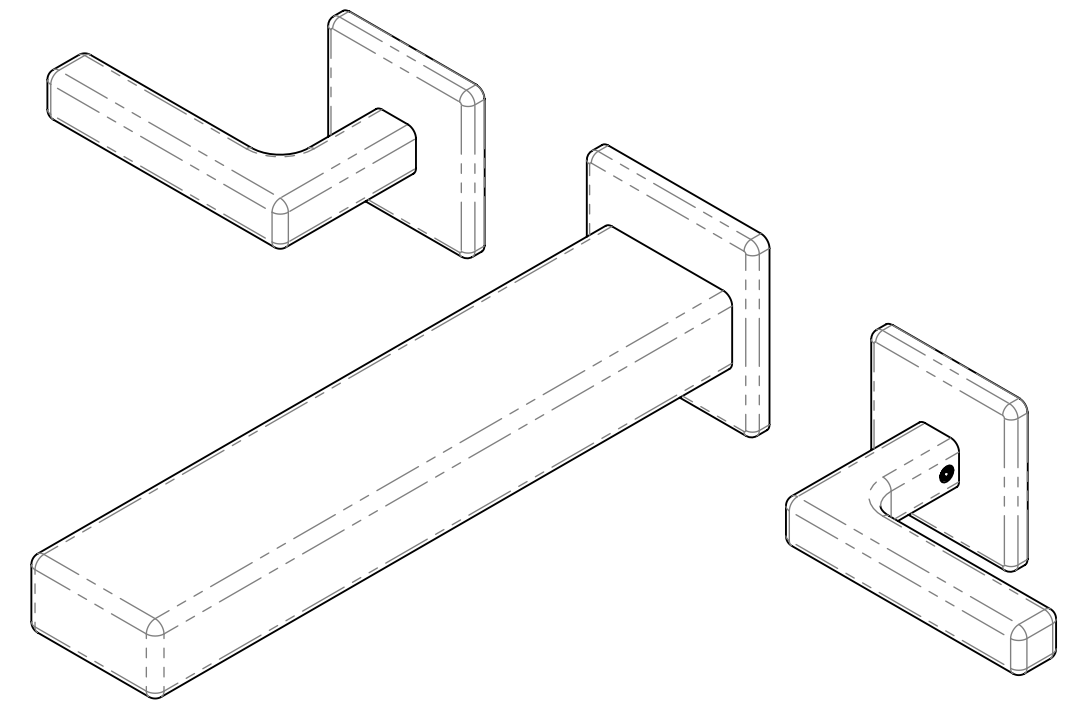
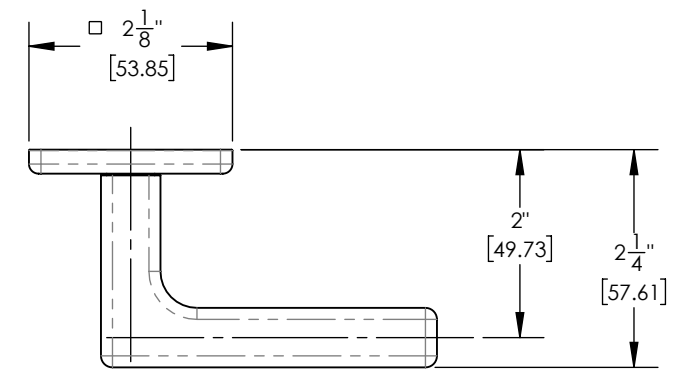
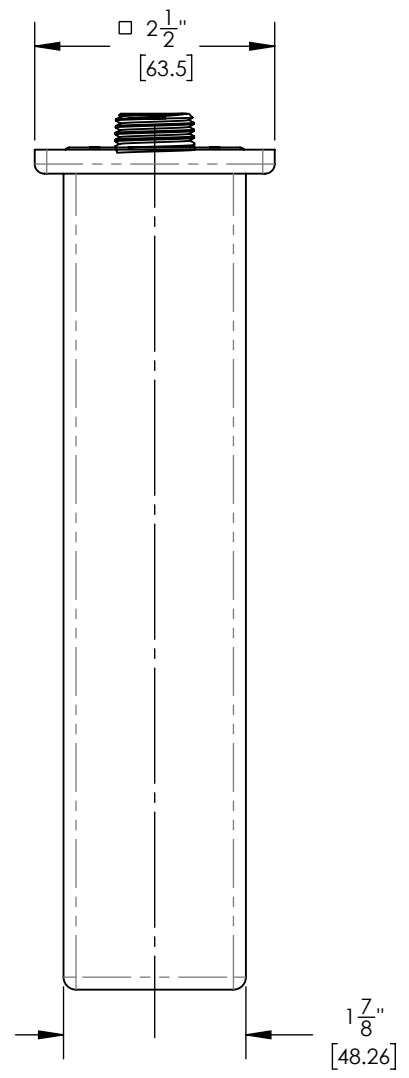
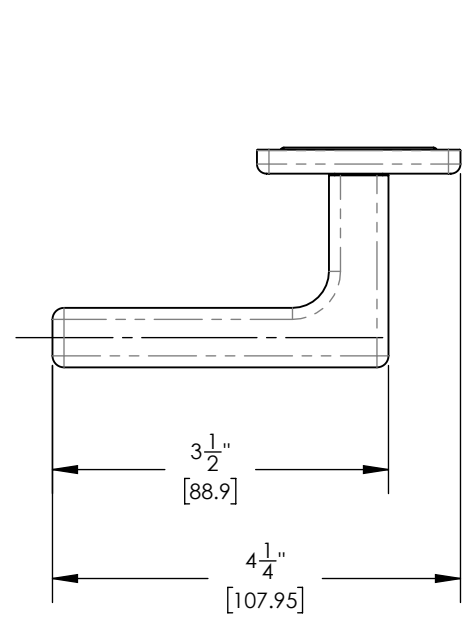

D

C

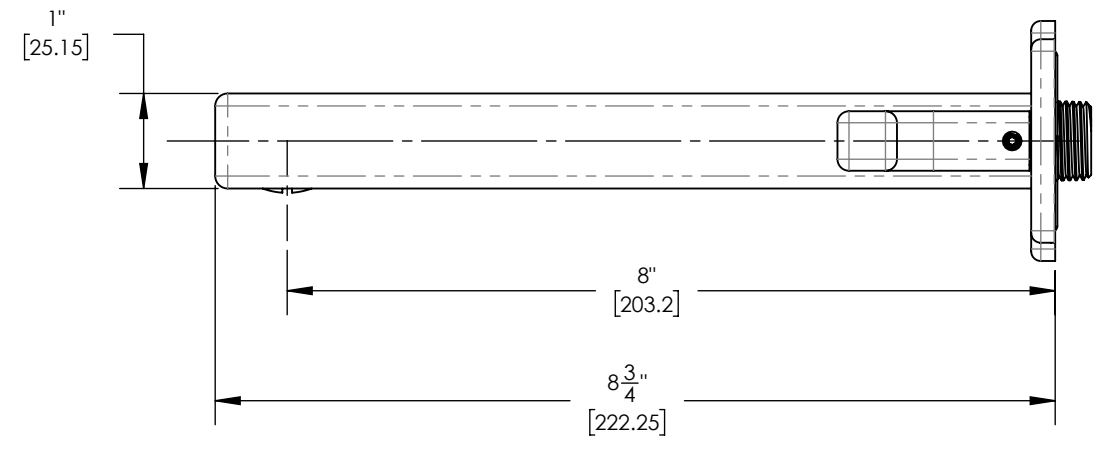
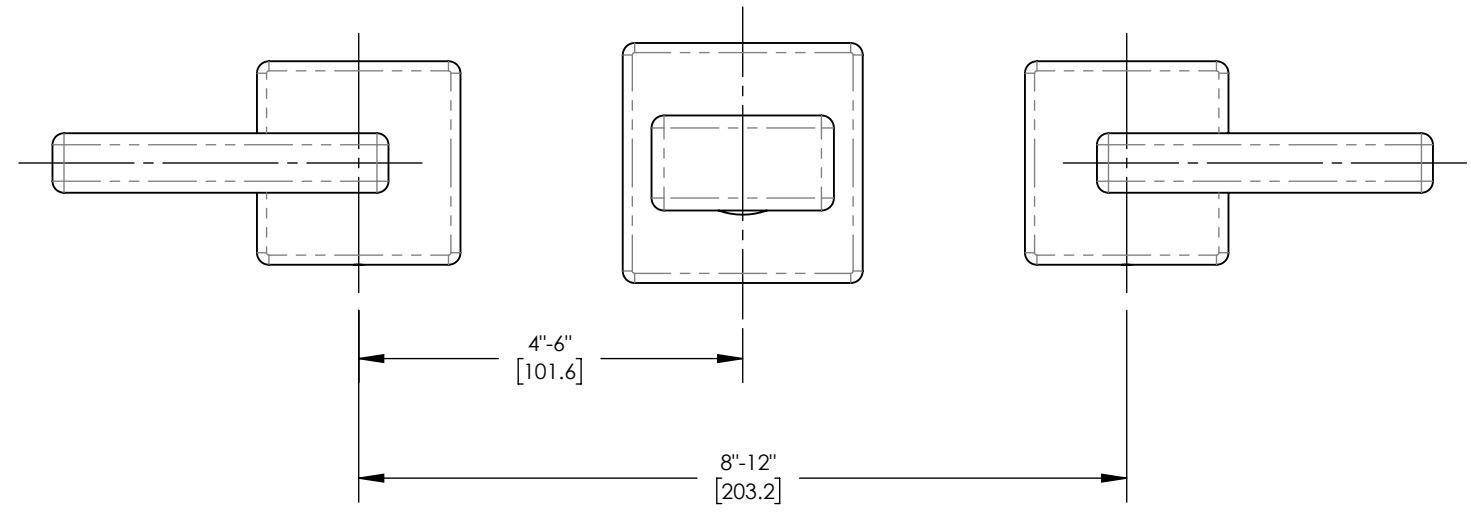

B

A

8 7 6 5 4 3 2 1

1261 LOGAN AVENUE  
COSTA MESA, CALIFORNIA 92626  
PHONE: 714.361.4800  
FAX: 714.617.3120

**PHYLIRICH**<sup>®</sup>  
Defining Luxury Since 1959

**PROPRIETARY AND CONFIDENTIAL**  
THE INFORMATION CONTAINED IN THIS DRAWING IS THE SOLE PROPERTY OF PHYLIRICH. ANY REPRODUCTION IN PART OR AS A WHOLE WITHOUT THE WRITTEN PERMISSION OF PHYLIRICH IS PROHIBITED.  
**DO NOT SCALE DRAWING**

WALL TUB SET, LEVER, MIX

SIZE <b>B</b>	ASM/PRT NO. 290-57/00	REV B
SCALE: 1:2	WEIGHT: lbs.	SHEET 2 OF 2