

NOTE(S):
 1. PART NUMBER, "/00" DENOTES PART SHALL HAVE FINISH.

2. APPLY NSF COMPLIANT GREASE TO ANY O-RING, SEALING JOINTS, AND/OR PIVOTAL POINTS. G

3. APPLY NSF COMPLIANT LOCTITE TO THREADED AREA. L

4. APPLY NSF COMPLIANT REMOVABLE (BLUE) LOCTITE TO THREADED AREA. B

5. SILVER SOLDER JOINTS SHALL BE FULLY WETTED VIA CAPILLARY ACTION AND COMPLETELY NON-POROUS. S

ITEM NO.	PART NUMBER	DESCRIPTION	QTY.
1	3-603/00	ASSY, SQUARE HANDLE & BASE, CAGE DESIGN, JOLIE	2
2	3-638/00	ASSY, WALL SPOUT & BASE, SQUARE, JOLIE	1
2.1	11000/00	SPOUT, WALL MOUNT	1
2.2	11806/00	SQUARE BASE, BOTTOM, JOLIE	1
2.3	11804/00	SQAURE INSERT, HANDLE, BASE	1
2.4	11906/00	COVER, WALL SPOUT BASE, SQUARE, JOLIE	1
2.5	92008	SET SCREW, CUP POINT 8-32, 3/16" L.	2
2.6	92434	SCREW, SS PHILLIPS FLAT HEAD W/ UNDERCUT 6-32 X 7/16" L	4
2.7	90032	O-RING, 1-7/8"ID X 2"OD X 1/16"THK, AS-568-032	1
2.8	92158	DOWEL PIN, 1/8" X 3/8"L	2
2.9	10013	INJECTOR SHANK, 1/2"NPT MALE TO M16.5 CACHE W/ O-SEAL	1
2.10	90113	O-RING, 9/16"ID X 3/4"OD X 3/32"THK, AS-568-113	3
3	P05051	AERATOR, CACHE COINED SLOT M24X1.0 FULL FLOW	1

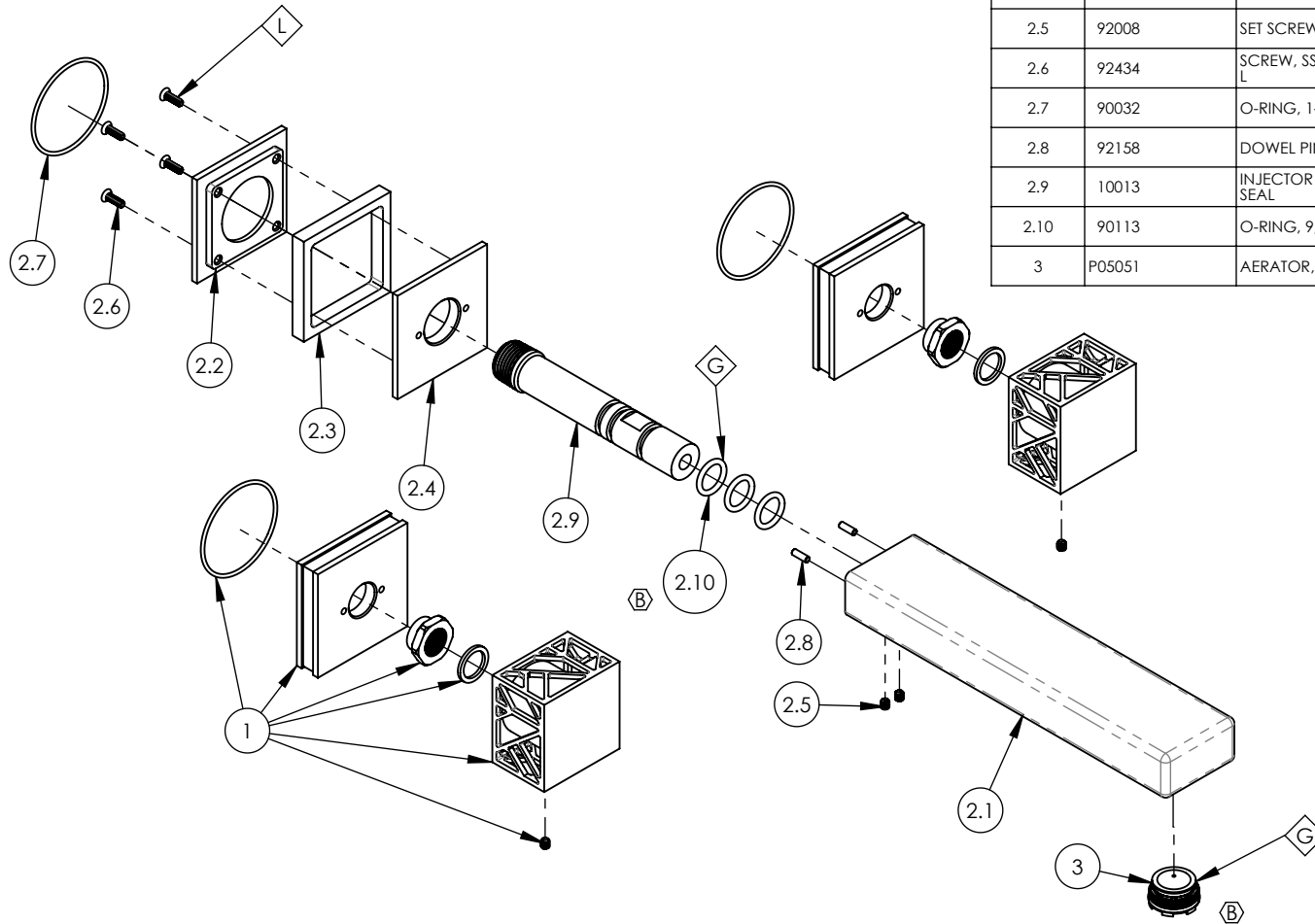

ZONE	REV.	DESCRIPTION	DATE	APPROVED
C4, B2	B	UPDATE O-RINGS & AERATOR	6/10/2021	AMM
REVISIONS				

1261 LOGAN AVENUE
 COSTA MESA, CALIFORNIA 92626
 PHONE: 714.361.4800
 FAX: 714.617.3120

PHYLIRICH[®]
 Defining Luxury Since 1959

PROPRIETARY AND CONFIDENTIAL
 THE INFORMATION CONTAINED IN THIS DRAWING IS THE SOLE PROPERTY OF PHYLIRICH. ANY REPRODUCTION IN PART OR AS A WHOLE WITHOUT THE WRITTEN PERMISSION OF PHYLIRICH IS PROHIBITED.
DO NOT SCALE DRAWING

ASSY, WALL TUB SET , SQUARE, JOLIE

SIZE A	ASM/PRT NO. 222-57/00	REV B
SCALE: 1:3.5	WEIGHT: lbs.	SHEET 1 OF 2

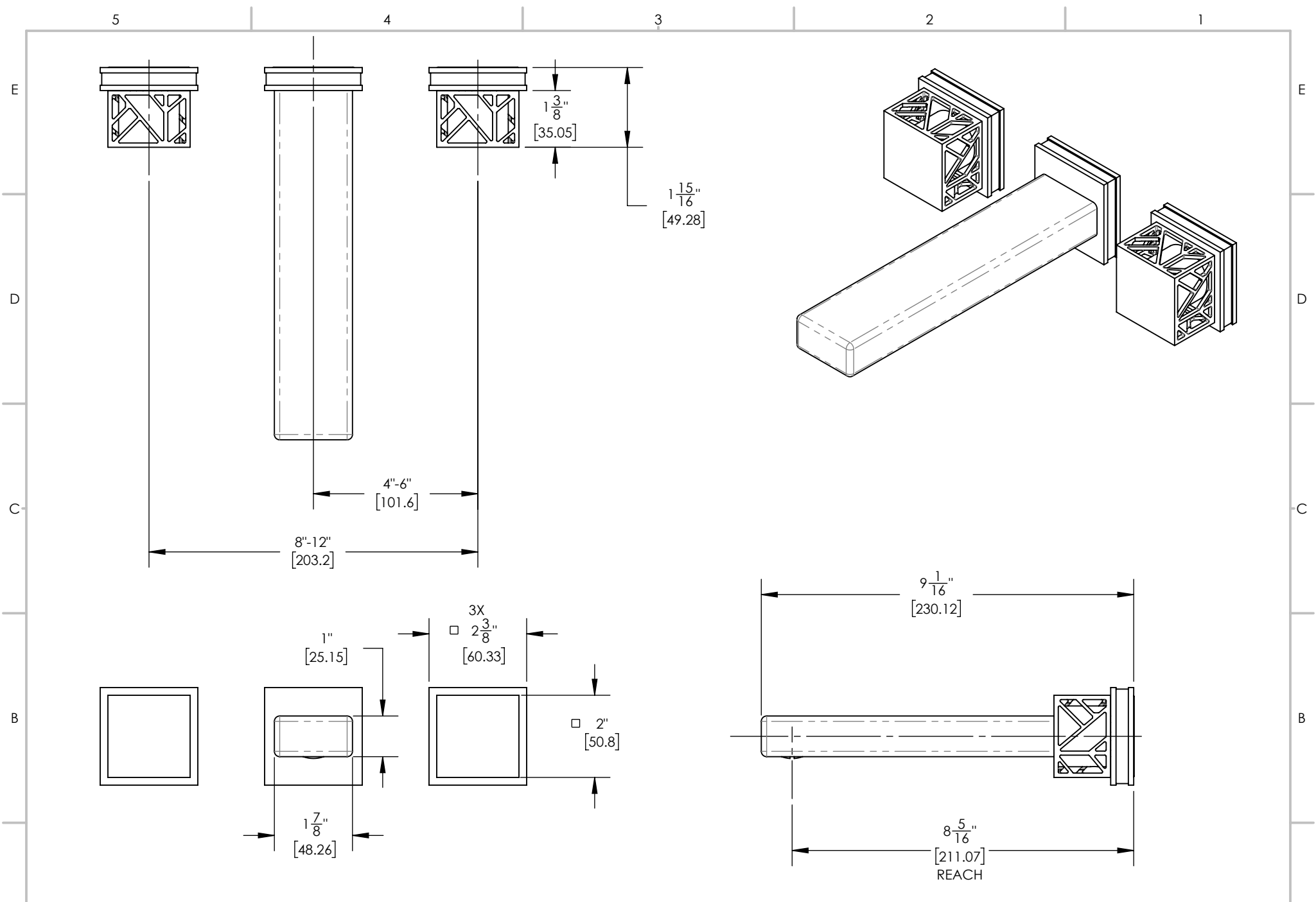

1261 LOGAN AVENUE
 COSTA MESA, CALIFORNIA 92626
 PHONE: 714.361.4800
 FAX: 714.617.3120

PHYLIRICH[®]
 Defining Luxury Since 1959

PROPRIETARY AND CONFIDENTIAL
 THE INFORMATION CONTAINED IN THIS DRAWING IS THE SOLE PROPERTY OF PHYLIRICH. ANY REPRODUCTION IN PART OR AS A WHOLE WITHOUT THE WRITTEN PERMISSION OF PHYLIRICH IS PROHIBITED.
DO NOT SCALE DRAWING

ASSY, WALL TUB SET, SQUARE, JOLIE

SIZE A	ASM/PRT NO. 222-57/00	REV B
SCALE: 1:3	WEIGHT: lbs.	SHEET 2 OF 2