

NOTE(S):
 1. PART NUMBER, "/00" DENOTES PART SHALL HAVE FINISH.
 2. APPLY NSF COMPLIANT LOCTITE TO THREADED AREA.

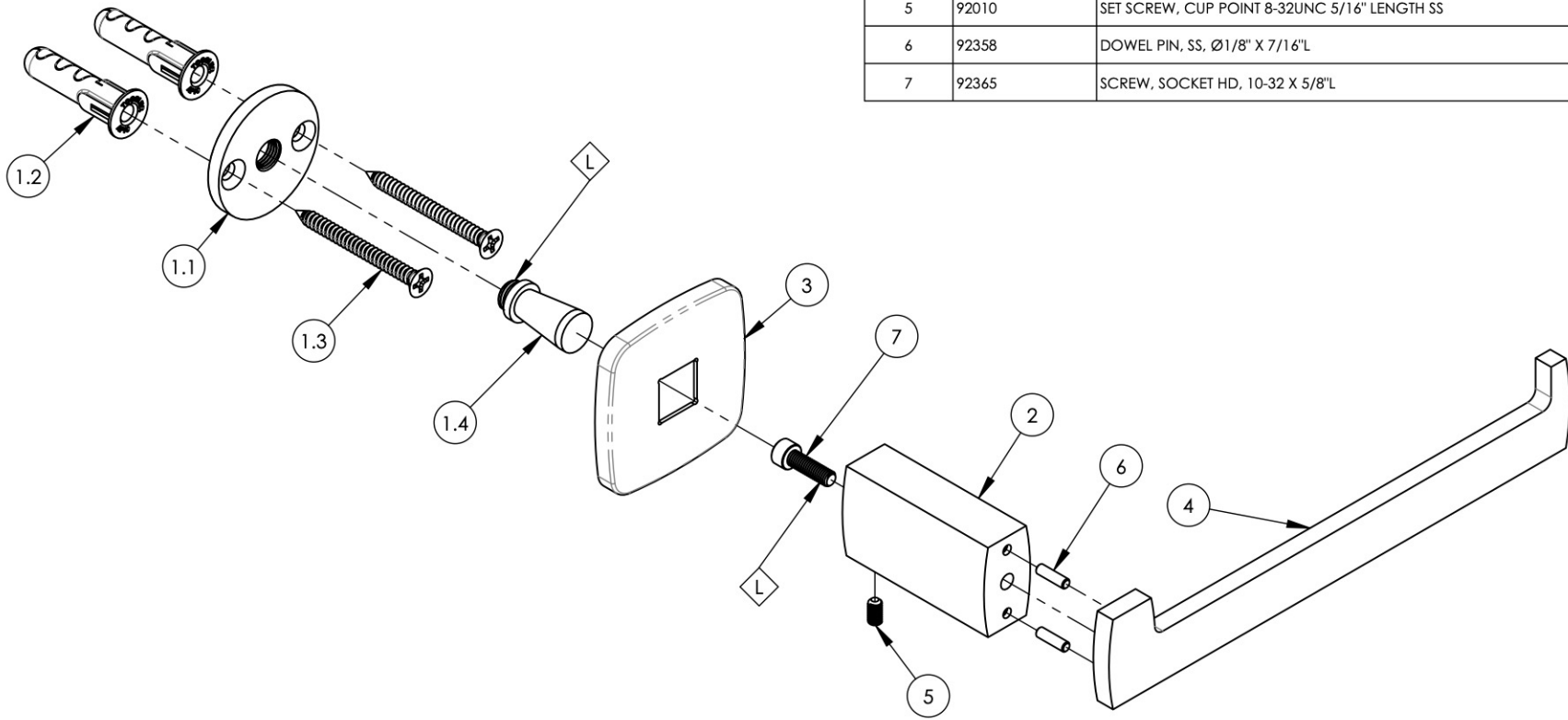

ITEM NO.	PART NUMBER	DESCRIPTION	QTY.
1	2-264	WALL MOUNTING KIT	1
1.1	92355	WALL MOUNT PLATE, TOWEL BAR, RADI	1
1.2	92046	ANCHOR SCREW 3/8" HOLE, TOGGLER AF10	2
1.3	92043	SCREW, FLAT HD #10 SIZE W/ #2 PHIL DRIVE, 2"L	2
1.4	92356	WALL MOUNT BUNG, TOWEL BAR, RADI	1
2	11641/00	POST EXTENSION, ACCESSORIES, RADI	1
3	11642/00	ESCUTCHEON, TOWEL BAR, RADI	1
4	12078/00	BAR FOR HAND TOWEL, ACCESSORIES, RADI	1
5	92010	SET SCREW, CUP POINT 8-32UNC 5/16" LENGTH SS	1
6	92358	DOWEL PIN, SS, Ø1/8" X 7/16"L	2
7	92365	SCREW, SOCKET HD, 10-32 X 5/8"L	1



ZONE	REV.	DESCRIPTION	DATE	APPROVED
REVISIONS				

1261 LOGAN AVENUE
 COSTA MESA, CALIFORNIA 92626
 PHONE: 714.361.4800
 FAX: 714.617.3120

PHYLIRICH[®]
 Defining Luxury Since 1959

PROPRIETARY AND CONFIDENTIAL
 THE INFORMATION CONTAINED IN THIS DRAWING IS THE SOLE PROPERTY OF PHYLIRICH. ANY REPRODUCTION IN PART OR AS A WHOLE WITHOUT THE WRITTEN PERMISSION OF PHYLIRICH IS PROHIBITED.

-	-	INTERPRET GEOMETRIC DIMENSIONING & TOLERANCING IN ACCORDANCE WITH ASME Y14.5-2009 & ASME Y14.41-2003 STANDARDS, UNLESS OTHERWISE SPECIFIED. DIMENSIONS ARE IN INCHES. TOLERANCES ARE:		
NEXT ASSY	USED ON	FRACTIONS ±1/16"	DECIMALS X.X: ±.1 X.XX: ±.01 X.XXX: ±.005	ANGULAR ±2°
APPLICATION		MATERIAL	NAME	DATE
FINISH		DRAWN	RAH	12/15/2017
DO NOT SCALE DRAWING		CHECKED		

ACCESSORIES, HAND TOWEL HOLDER, SINGLE POST, RADI

SIZE	ASM/PRT NO.	REV
A	181-75/00	-

SCALE: 1:2 WEIGHT: lbs. SHEET 1 OF 2