

5

4

3

2

1

NOTE(S):  
1. PART NUMBER, "/00" DENOTES PART SHALL HAVE FINISH.

2. APPLY NSF COMPLIANT GREASE TO ANY O-RING, SEALING JOINTS, AND/OR PIVOTAL POINTS.

3. APPLY NSF COMPLIANT LOCTITE TO THREADED AREA.

4. APPLY NSF COMPLIANT REMOVABLE (BLUE) LOCTITE TO THREADED AREA.

5. SILVER SOLDER JOINTS SHALL BE FULLY WETTED VIA CAPILLARY ACTION AND COMPLETELY NON-POROUS.



ITEM NO.	PART NUMBER	DESCRIPTION	QTY.
1	3-519/00	ASSY, BLADE HANDLE, RADII	2
1.1	11620/00	ESCUTCHEON, HANDLE RADII	1
1.2	11619/00	HANDLE, BLADE, RADI	1
1.3	92005	SET SCREW, CUP PT 6-32 UNC THREAD 3/16"L	1
1.4	92176	WEAR WASHER	2
1.5	92177	RETAINING RING, 7/16" SHAFT	1
2	3-523/00	ASSY, WALL SPOUT, RADI	1
2.1	11628/00	WALL SPOUT, RADII	1
2.2	11629/00	ESCUTCHEON, WALL SPOUT, RADI	1
2.3	92158	DOWEL PIN, 1/8" X 3/8"L	2
2.4	90131	O-RING, 1-11/16ID X 3/32THK, AS-568-131	1
2.5	10013	INJECTOR SHANK, 1/2"NPT MALE TO M16.5 CACHE W/ O-SEAL	1
2.6	90113	O-RING, 9/16"ID X 3/4"OD X 3/32"THK, AS-568-113	3
2.7	92008	SET SCREW, CUP POINT 8-32, 3/16" L.	2
3	11003	SLEEVE MOUNT, WALL MT WIDESPREAD	2
4	90029	O-RING, 1-5/8"ID X 1-3/4"OD X 1/16"THK, AS-568-029	2
5	P05051	AERATOR, CACHE COINED SLOT M24X1.0 FULL FLOW	1

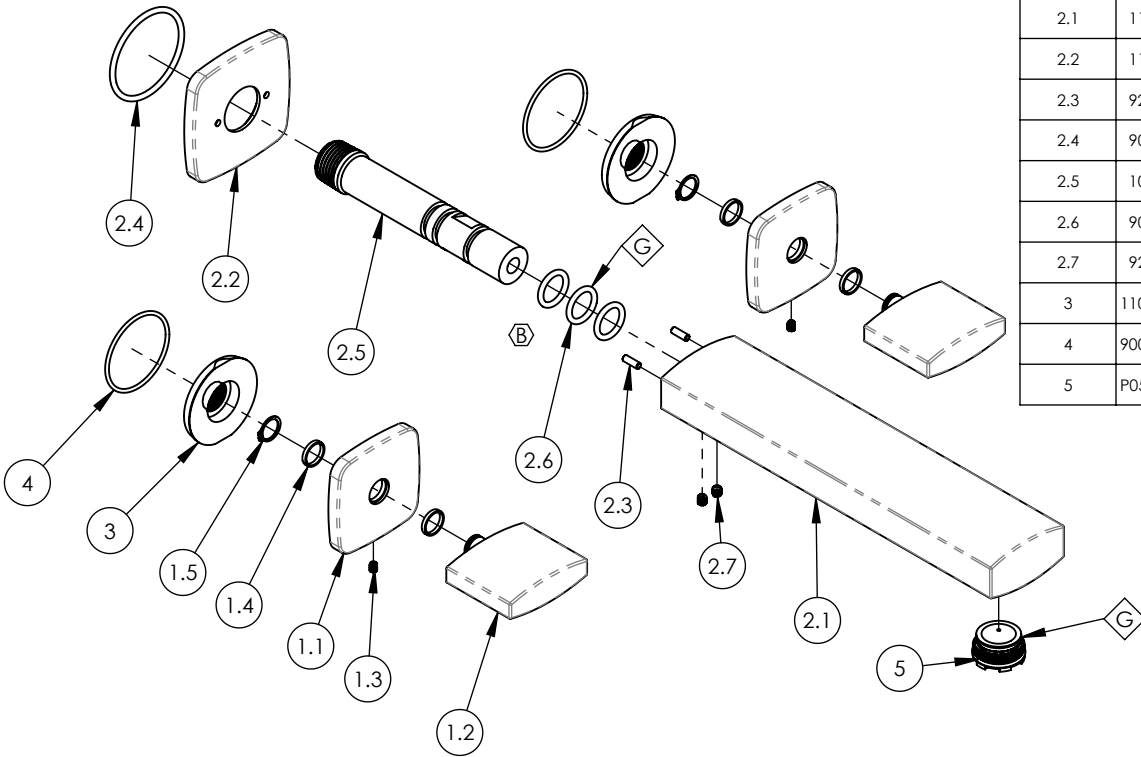

ZONE	REV.	DESCRIPTION	DATE	APPROVED
C4	B	UPDATE O-RINGS	6/10/2021	AMM
REVISIONS				

1261 LOGAN AVENUE  
COSTA MESA, CALIFORNIA 92626  
PHONE: 714.361.4800  
FAX: 714.617.3120

**PHYL RICH**<sup>®</sup>  
Defining Luxury Since 1959

**PROPRIETARY AND CONFIDENTIAL**  
THE INFORMATION CONTAINED IN THIS DRAWING IS THE SOLE PROPERTY OF PHYL RICH. ANY REPRODUCTION IN PART OR AS A WHOLE WITHOUT THE WRITTEN PERMISSION OF PHYL RICH IS PROHIBITED.  
**DO NOT SCALE DRAWING**

WALL TUB SET, BLADE HANDLES, RADI

SIZE <b>A</b>	ASM/PRT NO. 181-56/00	REV B
SCALE: 1:3.5	WEIGHT: lbs.	SHEET 1 OF 2

5

4

3

2

1

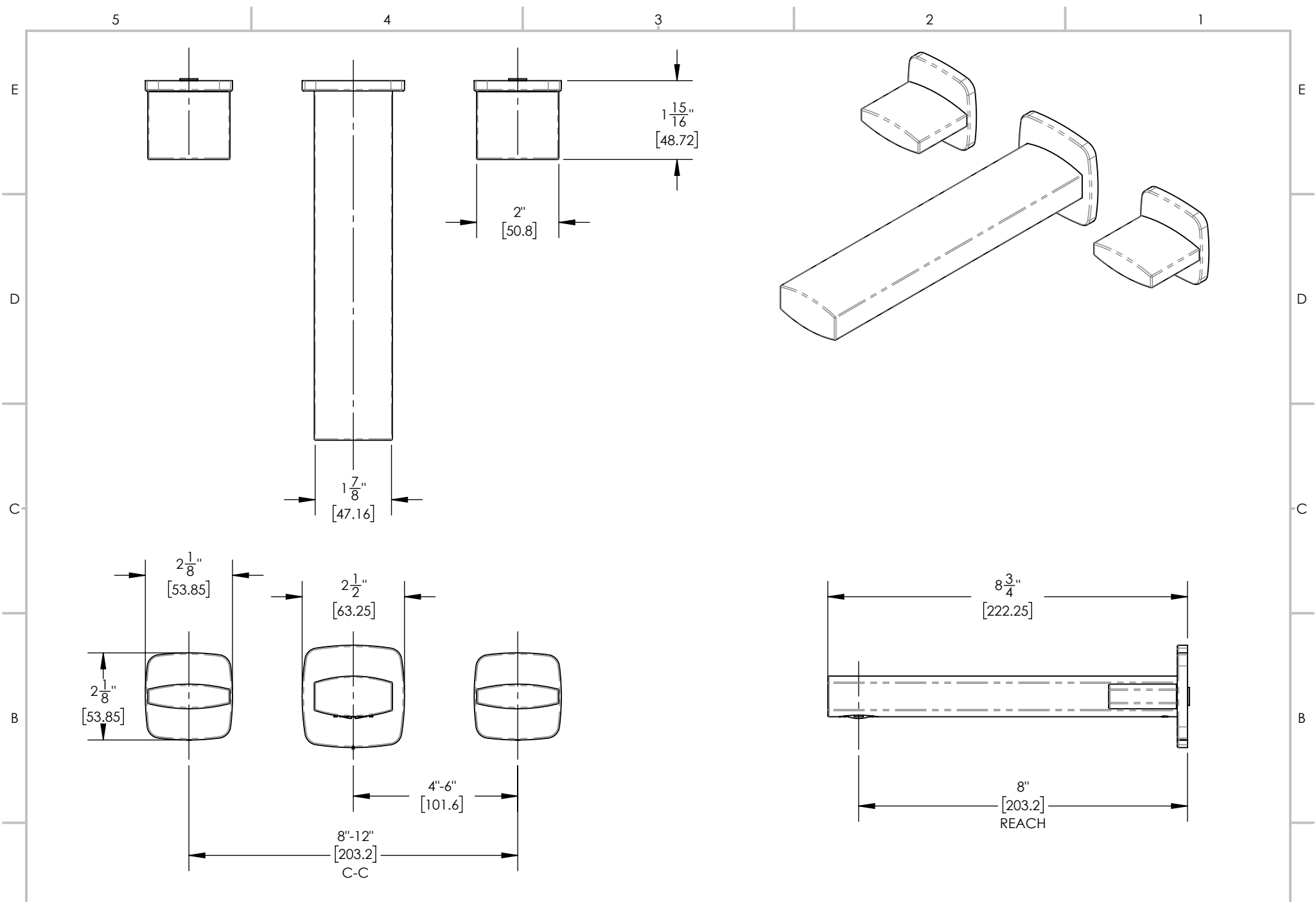

1261 LOGAN AVENUE  
 COSTA MESA, CALIFORNIA 92626  
 PHONE: 714.361.4800  
 FAX: 714.617.3120

**PHYLIRICH**<sup>®</sup>  
 Defining Luxury Since 1959

**PROPRIETARY AND CONFIDENTIAL**  
 THE INFORMATION CONTAINED IN THIS DRAWING  
 IS THE SOLE PROPERTY OF PHYLIRICH. ANY  
 REPRODUCTION IN PART OR AS A WHOLE  
 WITHOUT THE WRITTEN PERMISSION OF PHYLIRICH  
 IS PROHIBITED.  
**DO NOT SCALE DRAWING**

WALL TUB SET, BLADE HANDLES, RADI

SIZE <b>A</b>	ASM/PRT NO. 181-56/00	REV B
SCALE: 1:3	WEIGHT: lbs.	SHEET 2 OF 2