

- NOTE(S):
- OVERALL DIMENSIONS PART IS AS FOLLOWS:
 A. DIAMETER / HEIGHT & WIDTH = \varnothing
 B. LENGTH =
 - UNLESS OTHERWISE SPECIFIED, REMOVE ALL SHARP EDGES AND BURRS: .005 - .015.
 - ANY / ALL DIMENSION CALLOUTS WITH $\triangle 1$ SHALL BE CRITICAL DIMENSIONS.

ITEM NO.	PART NUMBER	DESCRIPTION	QTY.
1	10054	STEM EXTENSION, 20PT INT. TO 16PT LONG EXT. BROACH	1
2	10058	NUT, ADAPTOR CART. TO THREADALL, M24X1.0 - 9/16"-20UN	1
3	10257	CARTRIDGE, VALVE 1/2"G W/ M24X1.0 & M4 20PT COLD	1
4	2-192	SUB ASSY. 1/2" VOLUME CONTROL, WALL BIDET	1
5	92157	SCREW, SMALL HD M4X0.7 - 1/2"L	1

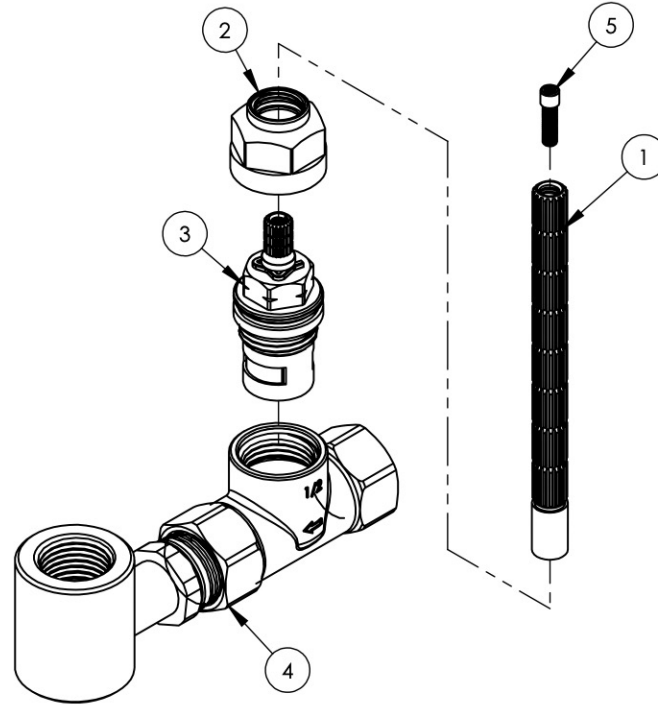

ZONE	REV.	DESCRIPTION	DATE	APPROVED
REVISIONS				

1261 LOGAN AVENUE
 COSTA MESA, CALIFORNIA 92626
 PHONE: 714.361.4800
 FAX: 714.617.3120



MANUFACTURING

PROPRIETARY AND CONFIDENTIAL

THE INFORMATION CONTAINED IN THIS DRAWING IS THE SOLE PROPERTY OF RSS MANUFACTURING. ANY REPRODUCTION IN PART OR AS A WHOLE WITHOUT THE WRITTEN PERMISSION OF RSS MANUFACTURING IS PROHIBITED.

-	-	INTERPRET GEOMETRIC DIMENSIONING & TOLERANCING IN ACCORDANCE WITH ASME Y14.5-2009 & ASME Y14.41-2003 STANDARDS. UNLESS OTHERWISE SPECIFIED, DIMENSIONS ARE IN INCHES. TOLERANCES ARE:		
NEXT ASSY	USED ON	FRACTIONS ±1/64"	DECIMALS X.X: ±.1 X.XX: ±.01 X.XXX: ±.005	ANGULAR ±.5°
APPLICATION		MATERIAL	NAME	DATE
FINISH		DRAWN	LLO	2/2/2016
DO NOT SCALE DRAWING		CHECKED	GRE	

VALVE, WALL BIDET, 1/2" VOLUME CONTROL

SIZE	ASM/PRT NO.	REV
A	1-125	-
SCALE: 1:2	WEIGHT: lbs.	SHEET 1 OF 1

5

4

3

2

1